

Quick Installation Guide

Indoor/Outdoor Access Point



Scan for
EAP Start Guide

Note: EAP610-Outdoor is used as an example throughout the guide. Images may differ from your actual product.

©2026 TP-Link 7100003046 REV2.0.2

Package Contents

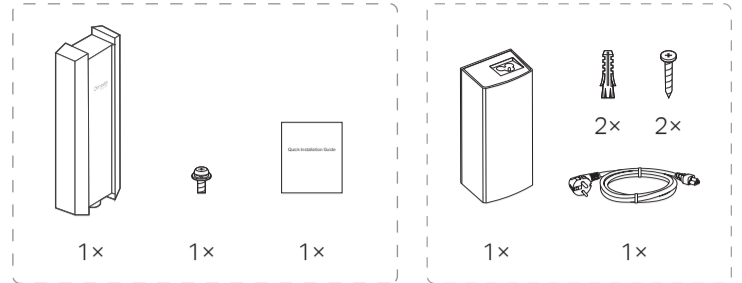

Waterproof Kit



Mounting Kit



Installation

Option 1: Pole Mounting

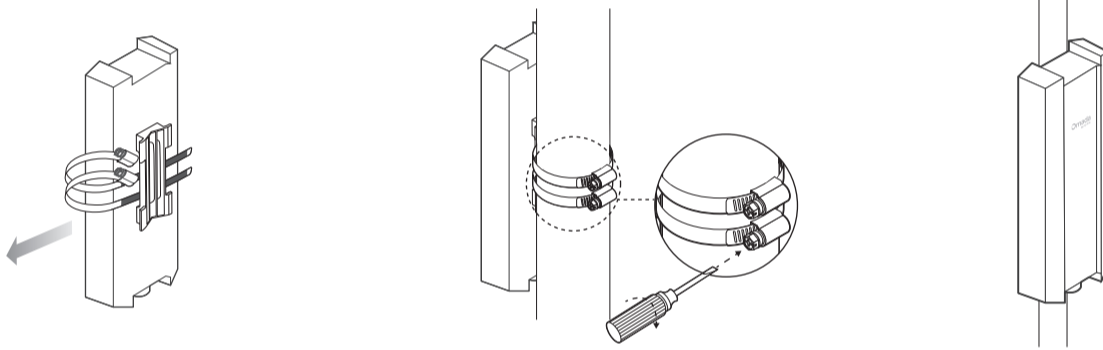

Option 2: Wall Mounting

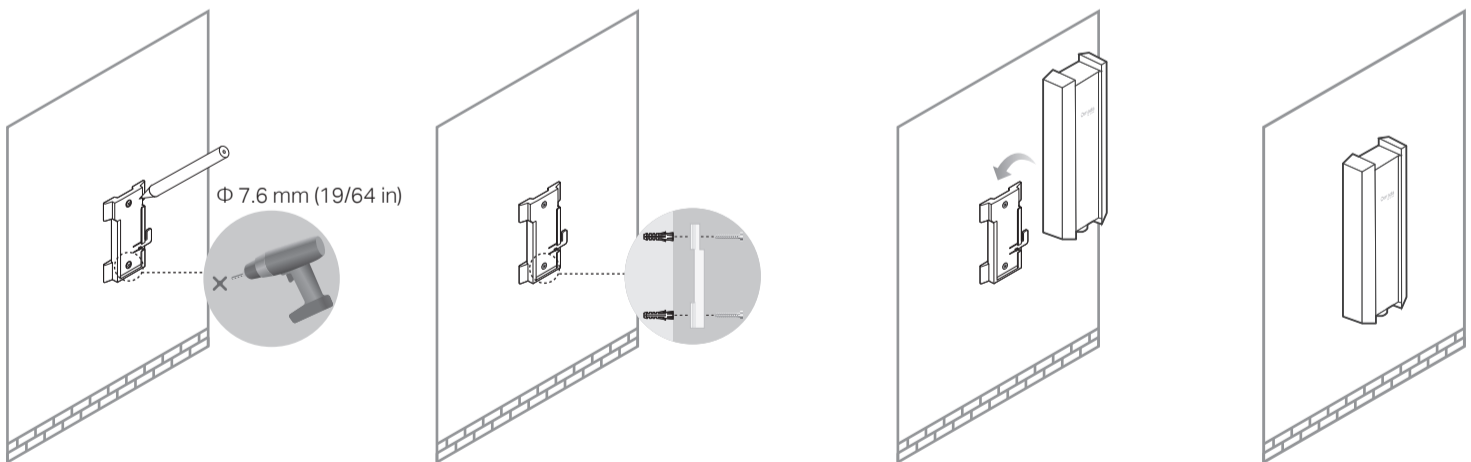

(Optional) Mount the PoE Adapter

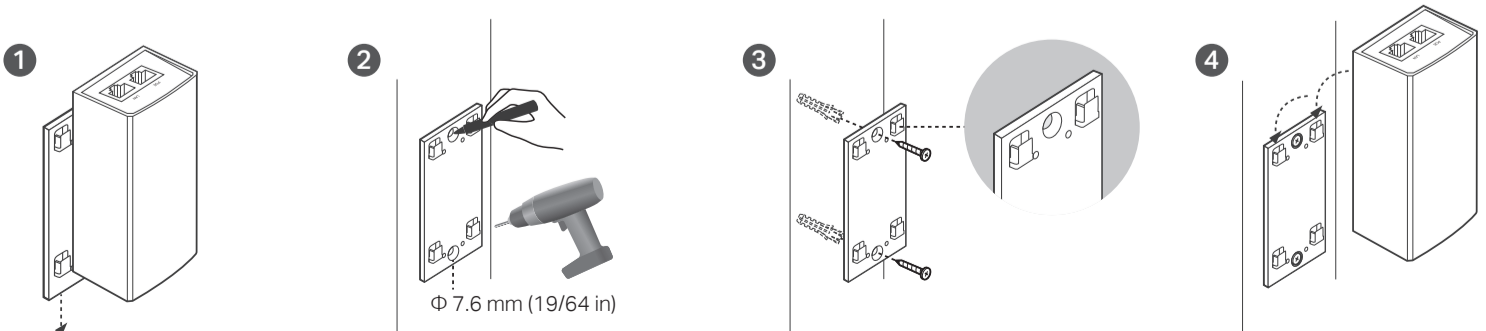

Connection

1. Waterproofing

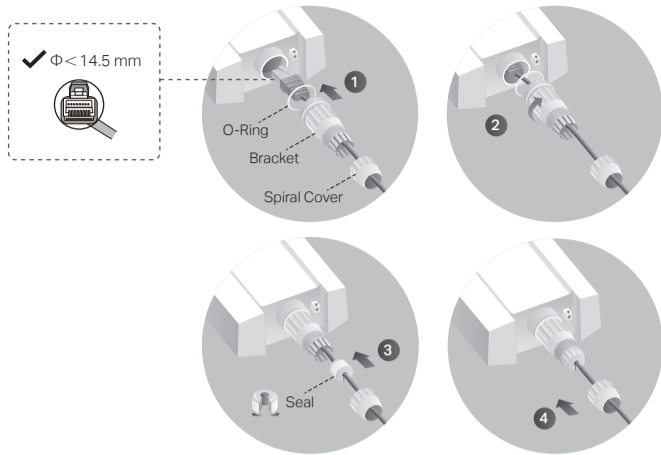

Note: To ensure waterproofing, choose the proper seal according to the type and diameter of the Ethernet cable.

2. Grounding

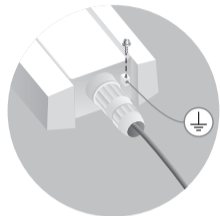

Note: For lightning and ESD protection, connect the EAP's grounding terminal to grounding facilities using a proper grounding wire, which should meet local installation requirements.

3. Power On

Option 1: Via Passive PoE Adapter

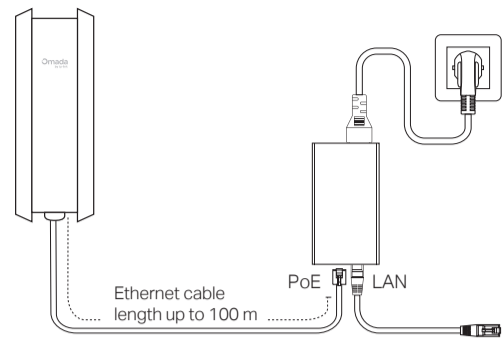

Option 2: Via PoE Switch

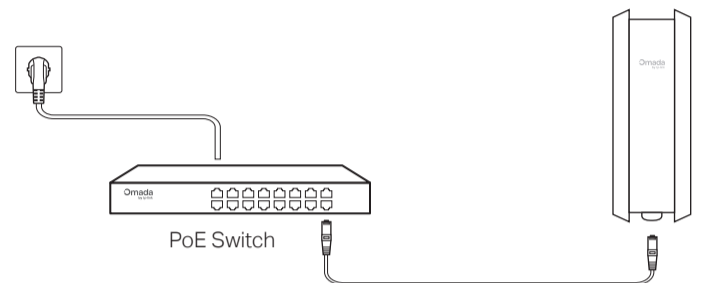

Configuration

Option 1: Standalone Mode

Configure and manage each EAP on its standalone page.

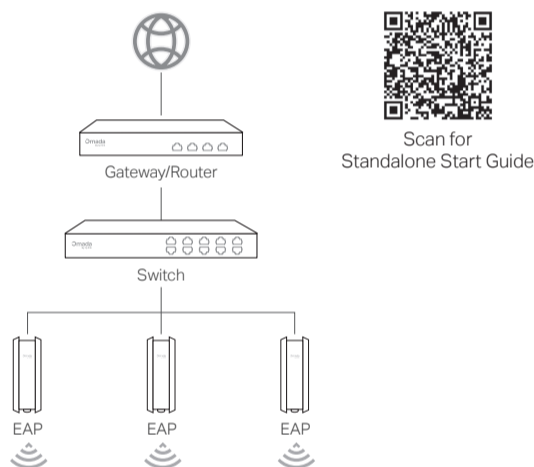

Option 2: Controller Mode

Configure and manage EAPs (and other Omada devices) centrally on an Omada Controller.

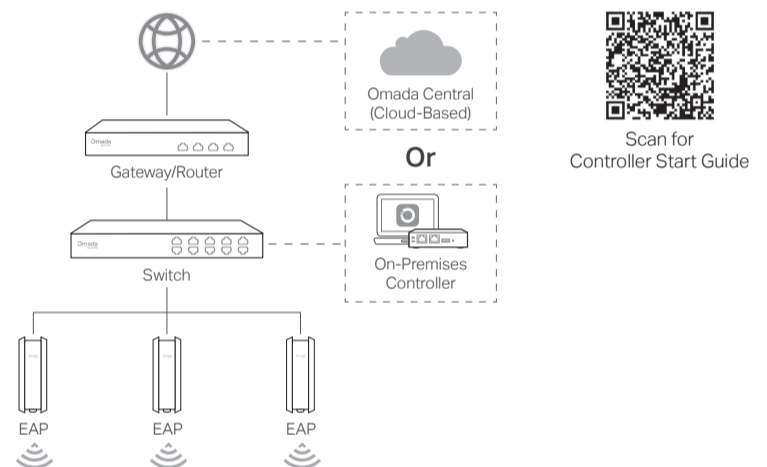

Omada App

With the TP-Link Omada app, you can access and manage your Omada devices at a local site or remotely with a tap of your phone.



Scan for Omada App

More Configurations

For more configurations, refer to the User Guides of the Omada Controller and Omada Access Points at: <https://support.omadanetworks.com/document/>



Safety Information

- Keep the device away from fire or hot environments. DO NOT immerse in water or any other liquid.
- Do not attempt to disassemble, repair, or modify the device. If you need service, please contact us.
- Do not use the device where wireless devices are not allowed.
- Do not use any other chargers than those recommended.
- Do not use a damaged charger or USB cable to charge the device.
- The adapter shall be installed near the equipment and shall be easily accessible.
- The adapter should be used indoors where the ambient temperature is lower than or equal to 40 °C.
- The socket-outlet shall be installed near the equipment and shall be easily accessible.
- Plug the adapter into a wall outlet with an earthing connection through the power supply cord.
- Use only power supplies which are provided by manufacturer and in the original packing of this product. If you have any questions, please don't hesitate to contact us.
- This EAP can be powered only by the passive PoE adapter or equipment that complies with Power Source Class 2 (PS2) or Limited Power Source (LPS) defined in the standard of IEC 62368-1. (For IN version) This EAP can be powered only by the passive PoE adapter or equipment that complies with Limited Power Source (LPS) of IEC 60950-1.
- Use only power supplies listed in the user instructions. Refer to the User Manual on the product support page.

TP-Link hereby declares that the Access Point is in compliance with the essential requirements and other relevant provisions of directives 2014/53/EU, 2009/125/EC, 2011/65/EU, and (EU)2015/863. The original EU Declaration of Conformity may be found at <https://www.tp-link.com/en/support/ce/>. TP-Link hereby declares that the Access Point is in compliance with the essential requirements and other relevant provisions of the Radio Equipment Regulations 2017. The original UK Declaration of Conformity may be found at <https://www.tp-link.com/support/ukca/>

Attention: In EU member states, EFTA countries and Northern Ireland, the operation in the frequency range 5150MHz-5350MHz is only permitted indoors.

Attention: In Great Britain, the operation in the frequency range 5150MHz - 5350MHz is only permitted indoors.

For the EAP Controller, go to the **Devices** page and select the desired EAP to specify the channel.

For the web browser, go to **Wireless > Wireless Settings** to specify the channel.

	AT	BE	BG	CH	CY	CZ	DE	DK		UK
	EE	EL	ES	FI	FR	HR	HU	IE		
	IS	IT	LI	LT	LU	LV	MT	NL		
	NO	PL	PT	RO	SE	SI	SK	UK(NI)		

More Resources

Main Site	https://www.omadanetworks.com/
Video Center	https://support.omadanetworks.com/video/
Documents	https://support.omadanetworks.com/document/
Product Support	https://support.omadanetworks.com/product/
Technical Support	https://support.omadanetworks.com/contact-support/

Warranty

For details on the warranty period, policy, and procedures, visit <https://support.omadanetworks.com/warranty-services/>.

Support

For technical support, user guides, and other information, please visit <https://support.omadanetworks.com/>, or simply scan the QR code.

